

REV/VER DESCRIPTION OF CHANGE

AA INITIAL RELEASE

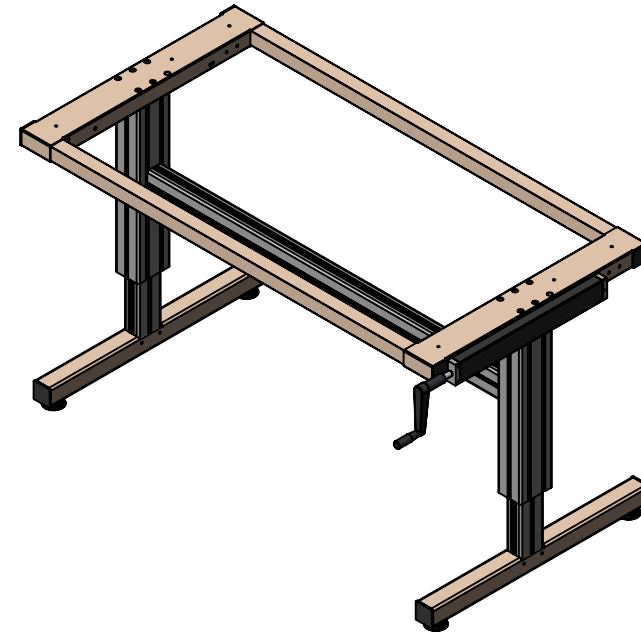
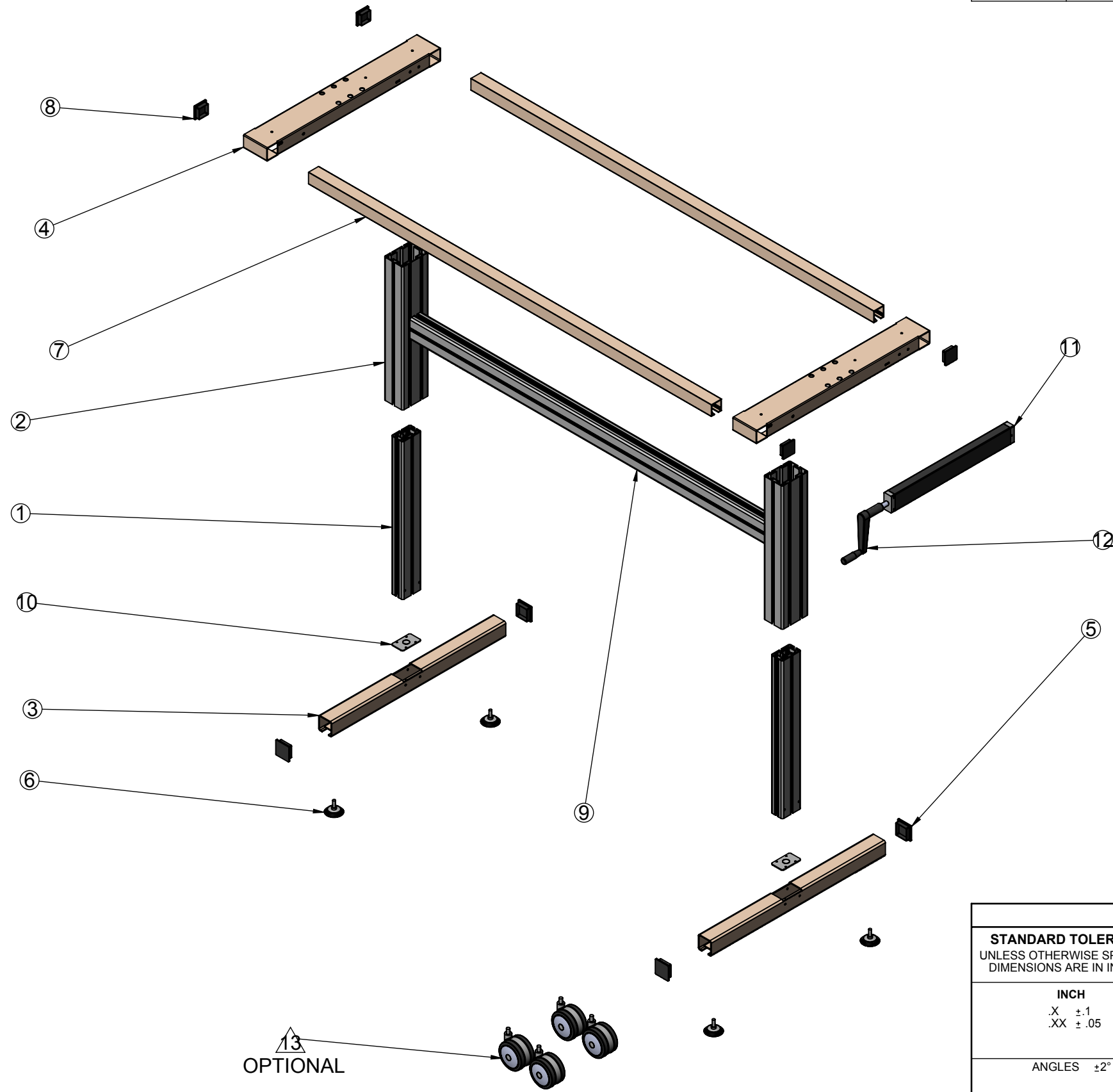

ITEM NO.	QTY.	ADDITIONAL DESCRIPTION	VENDOR	VENDOR PN
1	2	EXTR-LEG INNER	ERGOSOURCE	1003
2	2	EXTR-LEG OUTER	ERGOSOURCE	1001
3	2	FOOT	ERGOSOURCE	1009
4	2	ARM XET-XFT-XHT	ERGOSOURCE	1005
5	4	2.25" END CAP	ERGOSOURCE	SQR2-1/4-10
6	4	GLIDE FOOT	ERGOSOURCE	7661-6-B-2
7	2	RAIL	ERGOSOURCE	109542-05001CAPP
8	4	END CAP	ERGOSOURCE	SQR-2-10-14
9	1	STRUT	ERGOSOURCE	1003-XX
10	2	SUPPORT PLATE	ERGOSOURCE	1008
11	1	2X PUMP HOUSING	ERGOSOURCE	LM2T16
12	1	HANDLE	ERGOSOURCE	LH-05ES
13	4	CASTER	ERGOSOURCE	2F9957009-01

13
OPTIONAL

STANDARD TOLERANCES UNLESS OTHERWISE SPECIFIED DIMENSIONS ARE IN INCHES.		DRAWN BY LUCID LABS	DATE 02JUL2013		THIS DRAWING AND INFORMATION CONTAINED THEREON ARE CONFIDENTIAL AND THE PROPERTY OF ErgoSource. ANY USE OR REPRODUCTION OF THIS DRAWING IS EXPRESSLY PROHIBITED WITHOUT LUCID LABS CONSENT.
INCH .X ±.1 .XX ±.05	TITLE XHT TABLES				
ANGLES ±2°	MATERIAL NA		DWG SIZE B		DOCUMENT NUMBER XHT 72 INCH
SURFACE TREATMENT (UNLESS OTHERWISE SPECIFIED DIMENSIONS APPLY PRIOR TO TREATMENT) NA	DO NOT SCALE		REVISIONS	REVISIONS	REVISIONS
SHEET 1 OF 2			REVISIONS		

SOLIDWORKS

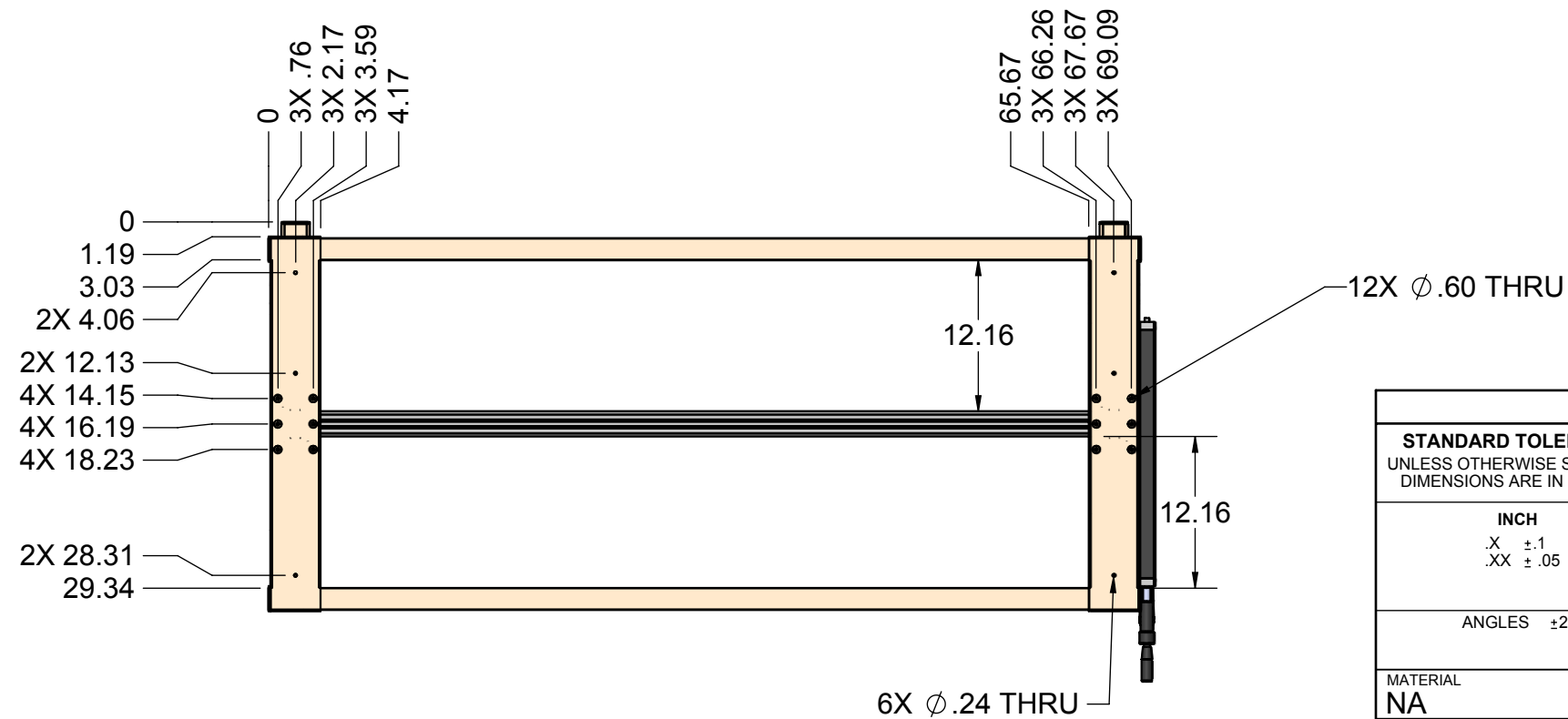
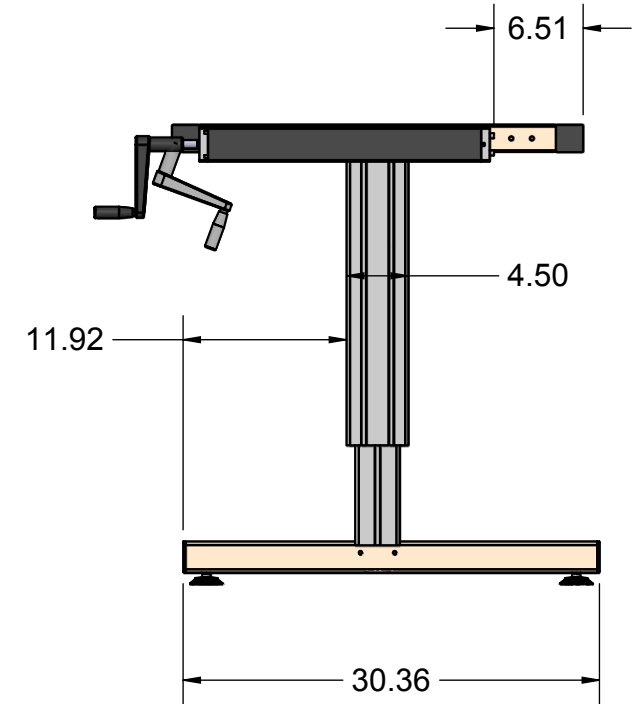
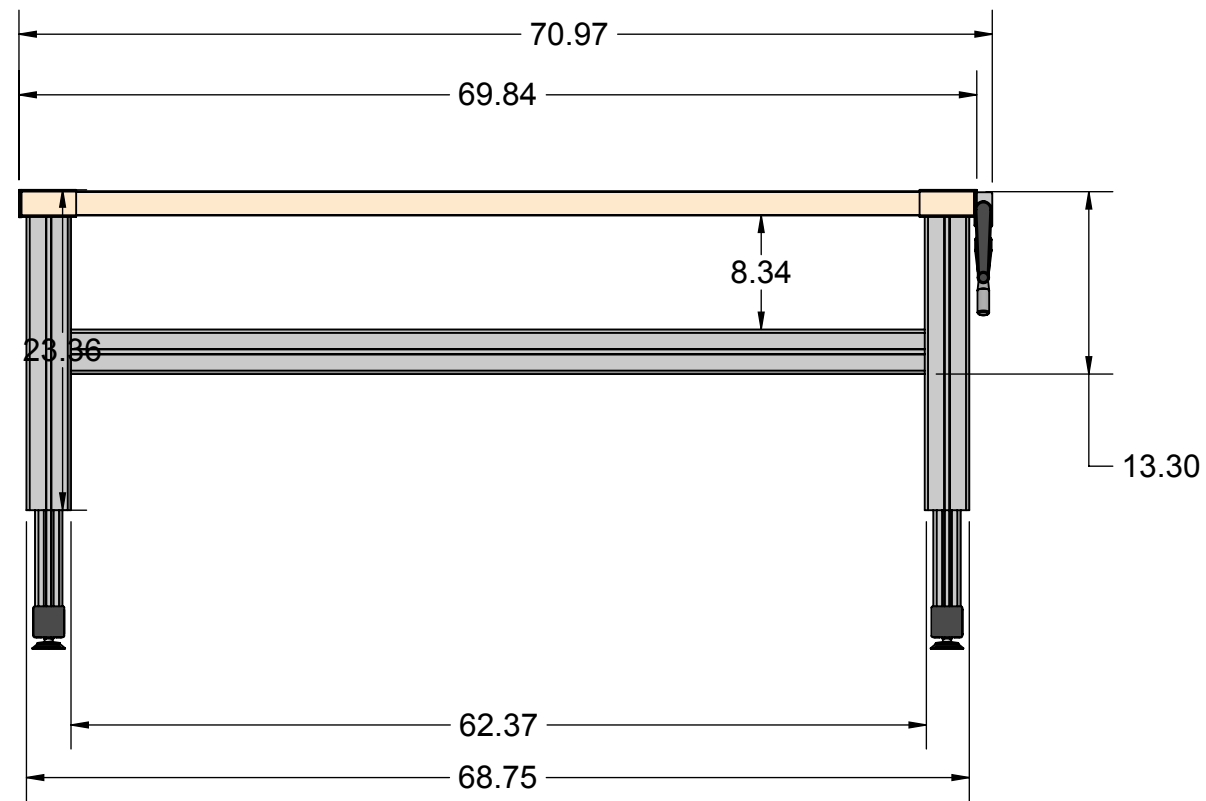
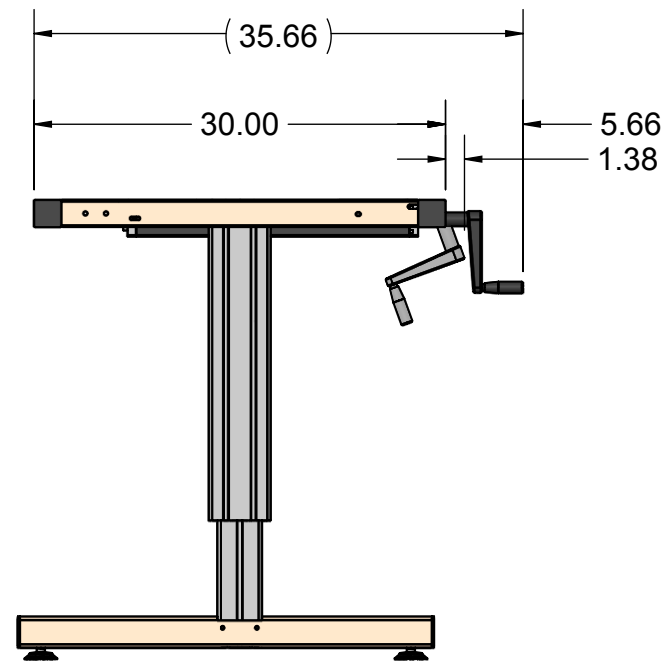

STANDARD TOLERANCES UNLESS OTHERWISE SPECIFIED DIMENSIONS ARE IN INCHES.		DRAWN BY LUCID LABS	DATE 02JUL2013	ErgoSource	THIS DRAWING AND INFORMATION CONTAINED THEREON ARE CONFIDENTIAL AND THE PROPERTY OF ErgoSource. ANY USE OR REPRODUCTION OF THIS DRAWING IS EXPRESSLY PROHIBITED WITHOUT LUCID LABS CONSENT.	
INCH .X ±.1 .XX ±.05		TITLE XHT TABLES				
ANGLES ±2°				DWG SIZE B	THIRD ANGLE PROJECTION	DOCUMENT NUMBER XHT 72 INCH
MATERIAL NA				DO NOT SCALE	REVISIONS	REV/VER
SURFACE TREATMENT (UNLESS OTHERWISE SPECIFIED DIMENSIONS APPLY PRIOR TO TREATMENT) NA				SHEET	2 OF 2	