

REV/VER	DESCRIPTION OF CHANGE
AA	INITIAL RELEASE

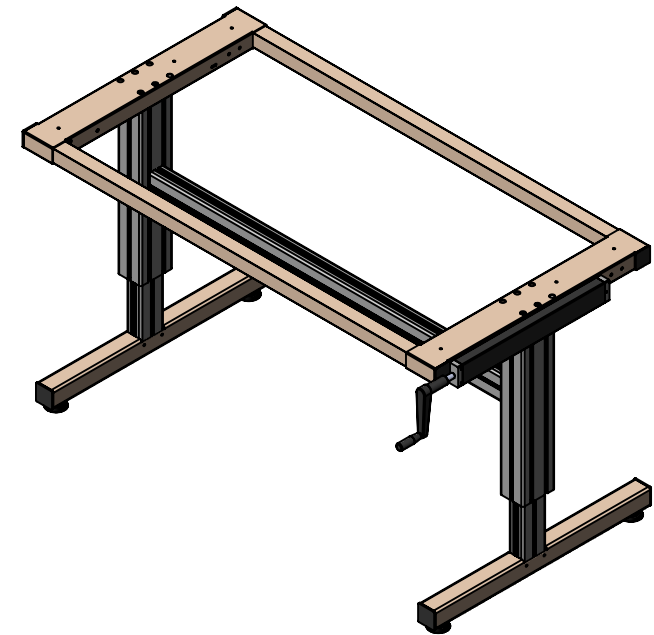
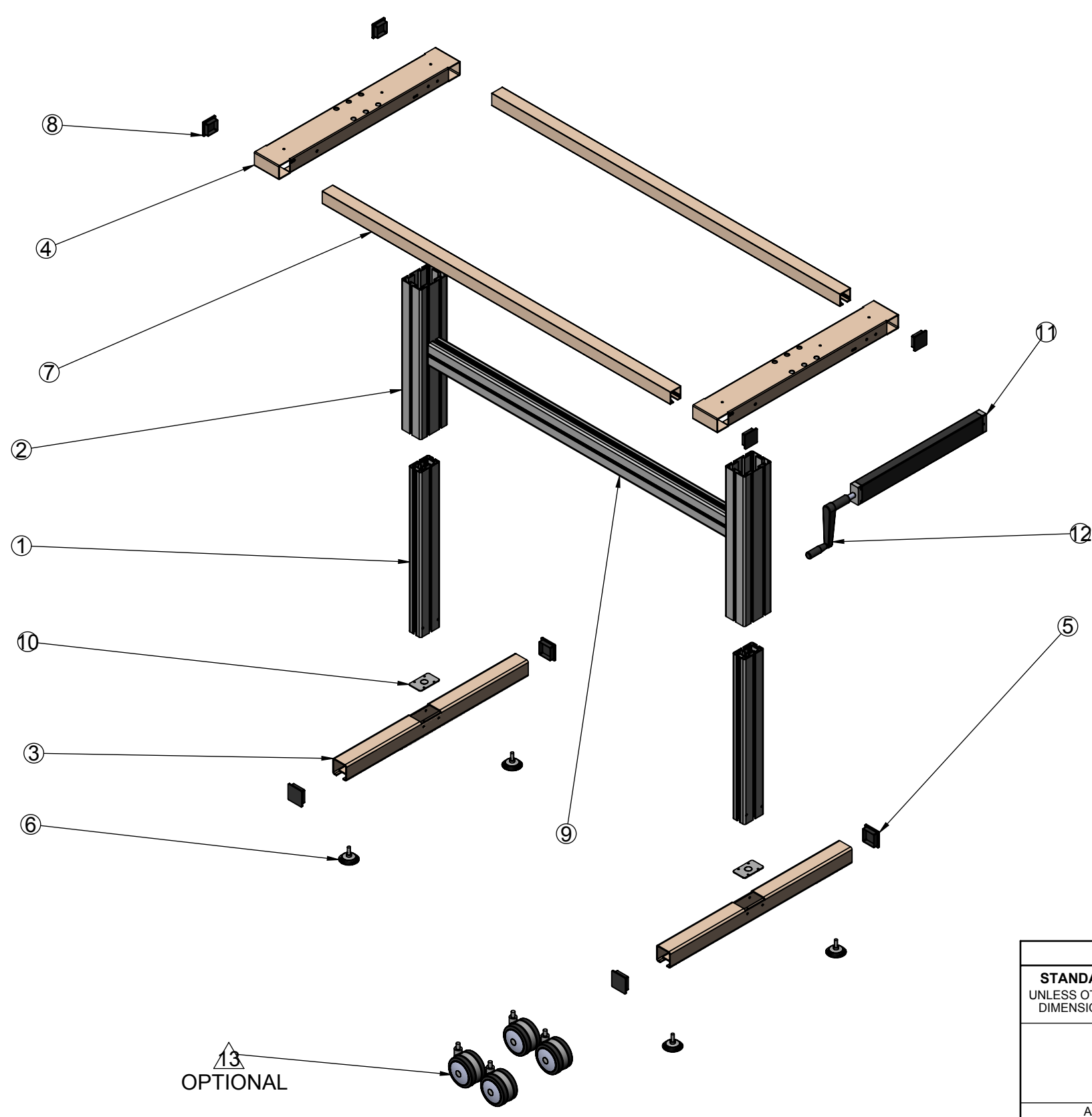

ITEM NO.	QTY.	ADDITIONAL DESCRIPTION	MANUFACTURER	VENDOR PN
1	2	EXTR-LEG INNER	NA	1003
2	2	EXTR-LEG OUTER	NA	1001
3	2	FOOT	NA	1009
4	2	ARM XET-XFT-XHT	NA	1005
5	4	2.25" END CAP	NA	SQR2-1/4-10
6	4	GLIDE FOOT	NA	7661-6-B-2
7	2	RAIL	NA	109542-05001CAPP
8	4	END CAP	NA	SQR-2-10-14
9	1	STRUT	NA	1003-XX
10	2	SUPPORT PLATE	NA	1008
11	1	2X PUMP HOUSING	NA	LM2T16
12	1	HANDLE	NA	LH-05ES
13	4	CASTER	NA	2F9957009-01

13
OPTIONAL

STANDARD TOLERANCES UNLESS OTHERWISE SPECIFIED DIMENSIONS ARE IN INCHES.		DRAWN BY LUCID LABS	DATE 02JUL2013	ErgoSource	THIS DRAWING AND INFORMATION CONTAINED THEREON ARE CONFIDENTIAL AND THE PROPERTY OF ErgoSource. ANY USE OR REPRODUCTION OF THIS DRAWING IS EXPRESSLY PROHIBITED WITHOUT LUCID LABS CONSENT.
INCH .X ±.1 .XX ±.05	TITLE XHT TABLES				
ANGLES ±2°	MATERIAL NA		DWG SIZE B		DOCUMENT NUMBER XHT 60 INCH
SURFACE TREATMENT (UNLESS OTHERWISE SPECIFIED DIMENSIONS APPLY PRIOR TO TREATMENT) NA		DO NOT SCALE		REVISION	SHEET 1 OF 2

SOLIDWORKS

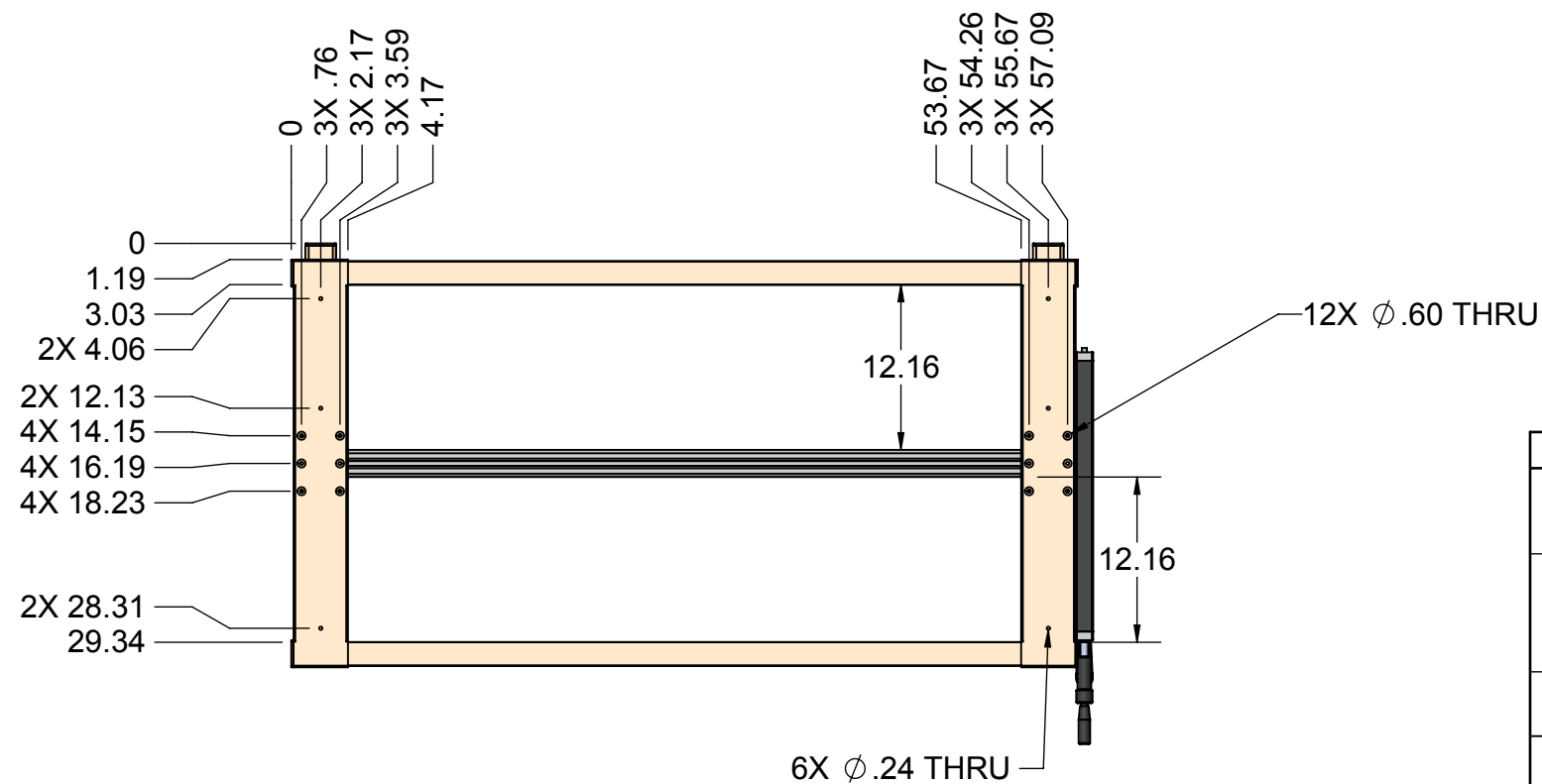
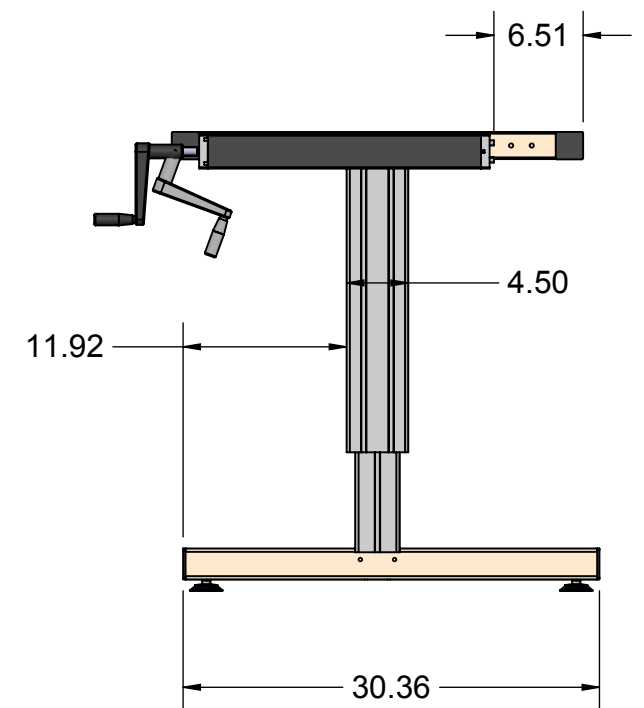
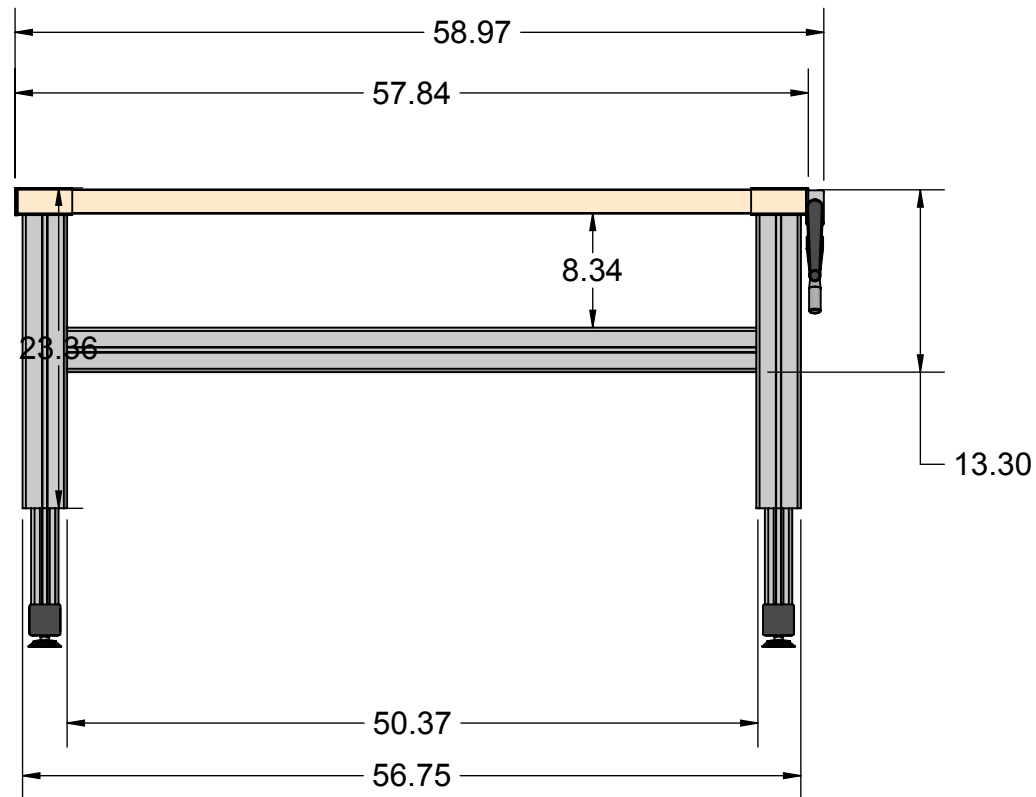
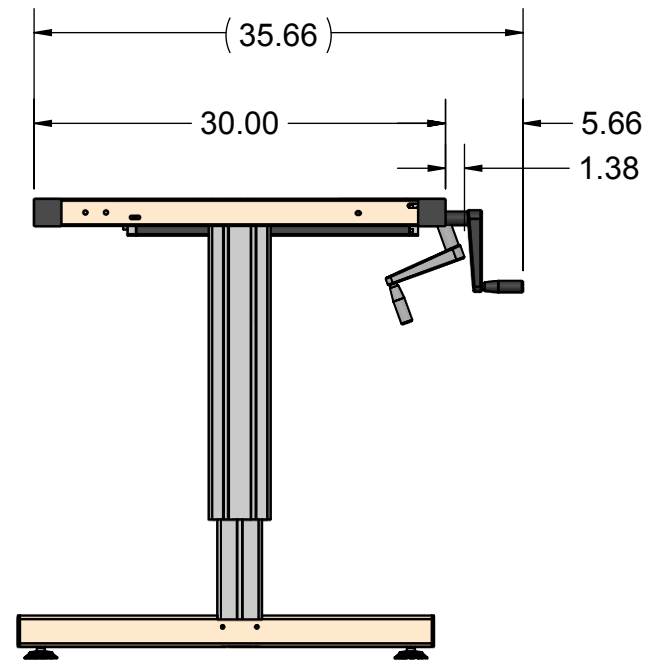

STANDARD TOLERANCES UNLESS OTHERWISE SPECIFIED DIMENSIONS ARE IN INCHES.		DRAWN BY LUCID LABS	DATE 02JUL2013	ErgoSource	THIS DRAWING AND INFORMATION CONTAINED THEREON ARE CONFIDENTIAL AND THE PROPERTY OF ErgoSource. ANY USE OR REPRODUCTION OF THIS DRAWING IS EXPRESSLY PROHIBITED WITHOUT LUCID LABS CONSENT.	
INCH .X ±.1 .XX ±.05		TITLE XHT TABLES				
ANGLES ±2°				DWG SIZE B	THIRD ANGLE PROJECTION	DOCUMENT NUMBER XHT 60 INCH
MATERIAL NA				DO NOT SCALE	REVISIONS	REV/VER
SURFACE TREATMENT (UNLESS OTHERWISE SPECIFIED DIMENSIONS APPLY PRIOR TO TREATMENT) NA				SHEET	2 OF 2	