

REV/VER	DESCRIPTION OF CHANGE
AA	INITIAL RELEASE

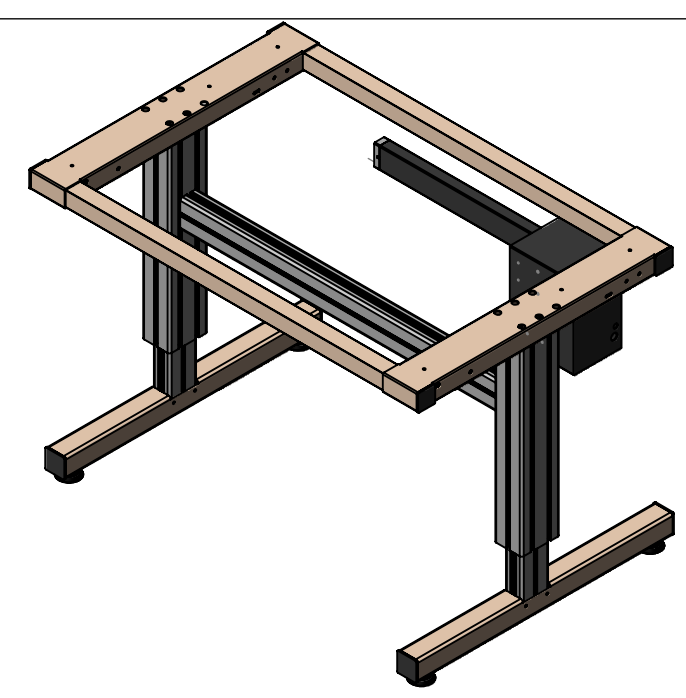
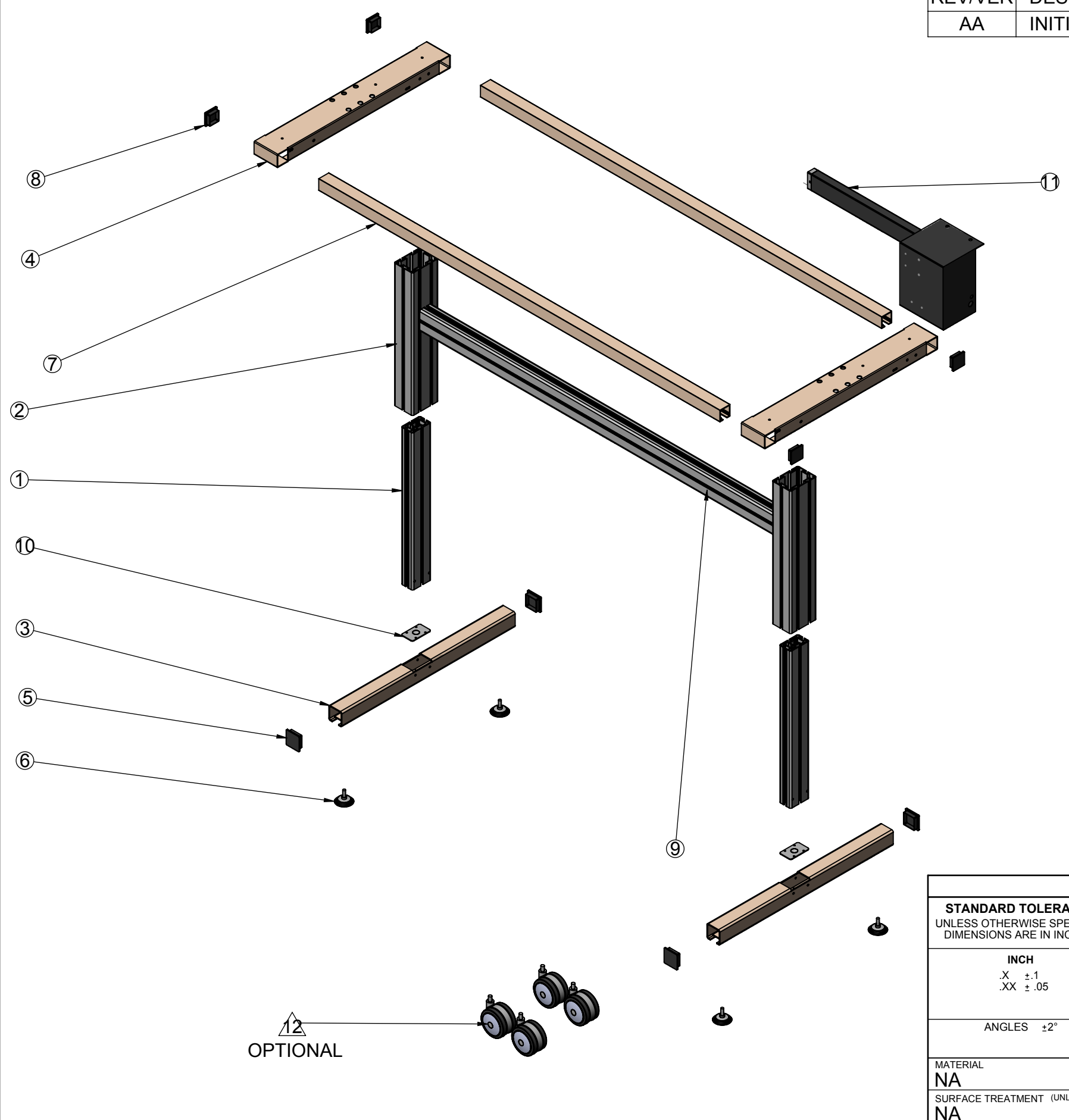

ITEM NO.	QTY.	ADDITIONAL DESCRIPTION	VENDOR	VENDOR PN
1	2	EXTR-LEG INNER	ERGOSOURCE	1003
2	2	EXTR-LEG OUTER	ERGOSOURCE	1001
3	2	FOOT	ERGOSOURCE	1009
4	2	ARM XET-XFT-XHT	ERGOSOURCE	1005
5	4	2.25" END CAP	ERGOSOURCE	SQR2-1/4-10
6	4	GLIDE FOOT	ERGOSOURCE	7661-6-B-2
7	2	RAIL	ERGOSOURCE	109542-05001CAPP
8	4	END CAP	ERGOSOURCE	SQR-2-10-14
9	1	STRUT	ERGOSOURCE	1003-XX
10	2	SUPPORT PLATE	ERGOSOURCE	1008
11	1	LIFT SYSTEM	ERGOSOURCE	LE2X16T - LPE2A-16
12	4	CASTER	ERGOSOURCE	2F9957009-01

12
OPTIONAL

STANDARD TOLERANCES UNLESS OTHERWISE SPECIFIED DIMENSIONS ARE IN INCHES.		DRAWN BY LUCID LABS	DATE 03JUL2013	ErgoSource	THIS DRAWING AND INFORMATION CONTAINED THEREON ARE CONFIDENTIAL AND THE PROPERTY OF ErgoSource. ANY USE OR REPRODUCTION OF THIS DRAWING IS EXPRESSLY PROHIBITED WITHOUT LUCID LABS CONSENT.
INCH .X ±.1 .XX ±.05 ANGLES ±2°		TITLE XET TABLE			
MATERIAL NA			DWG SIZE B	DOCUMENT NUMBER XET 72 INCH	REV/VER
SURFACE TREATMENT (UNLESS OTHERWISE SPECIFIED DIMENSIONS APPLY PRIOR TO TREATMENT) NA			THIRD ANGLE PROJECTION	SHEET 1 OF 2	DO NOT SCALE

SOLIDWORKS

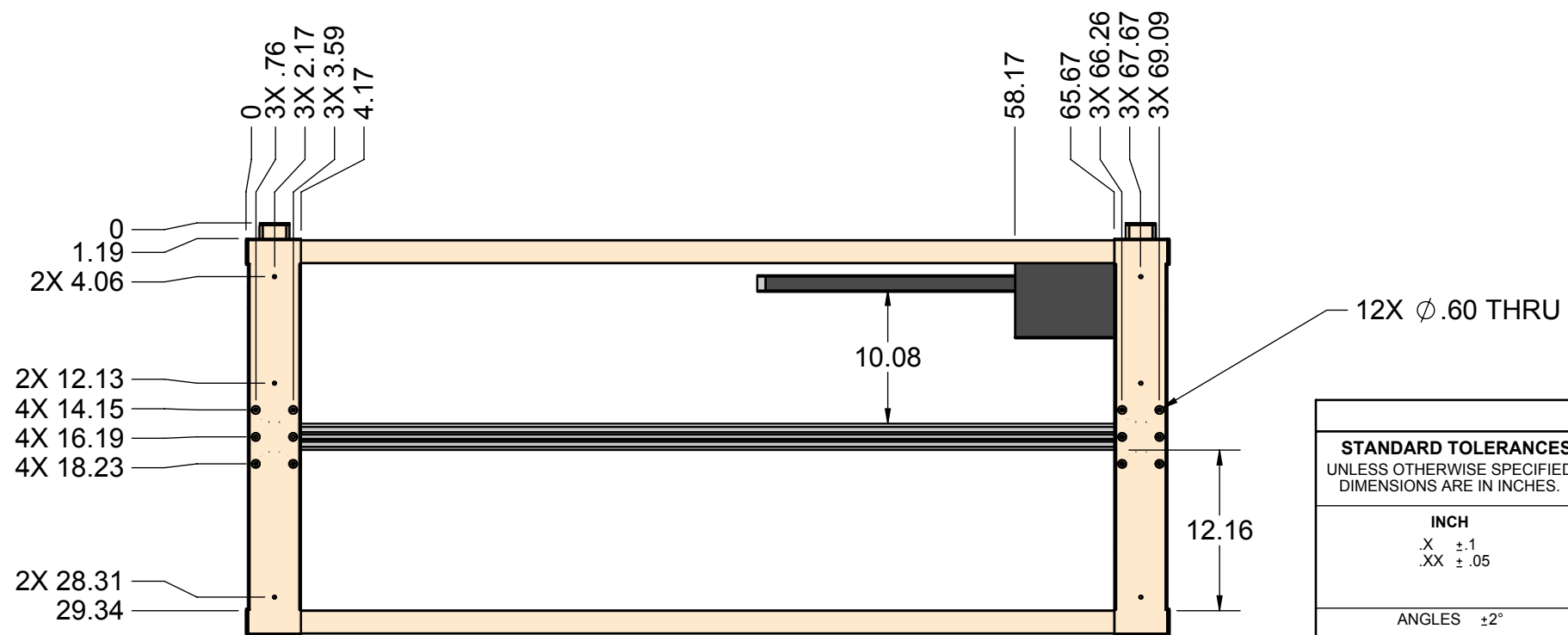
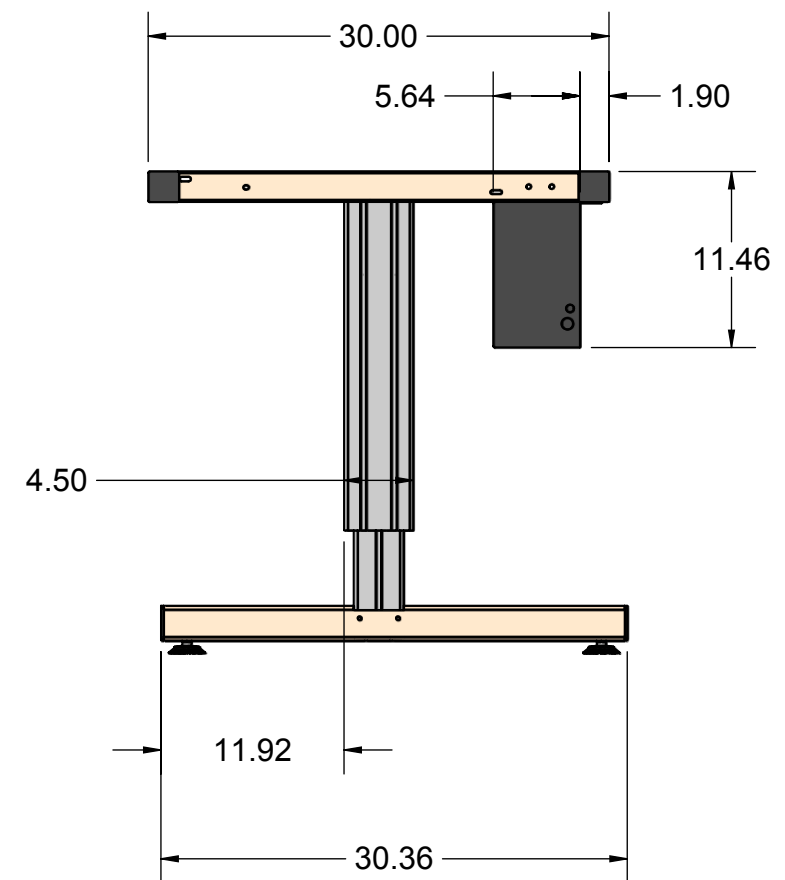
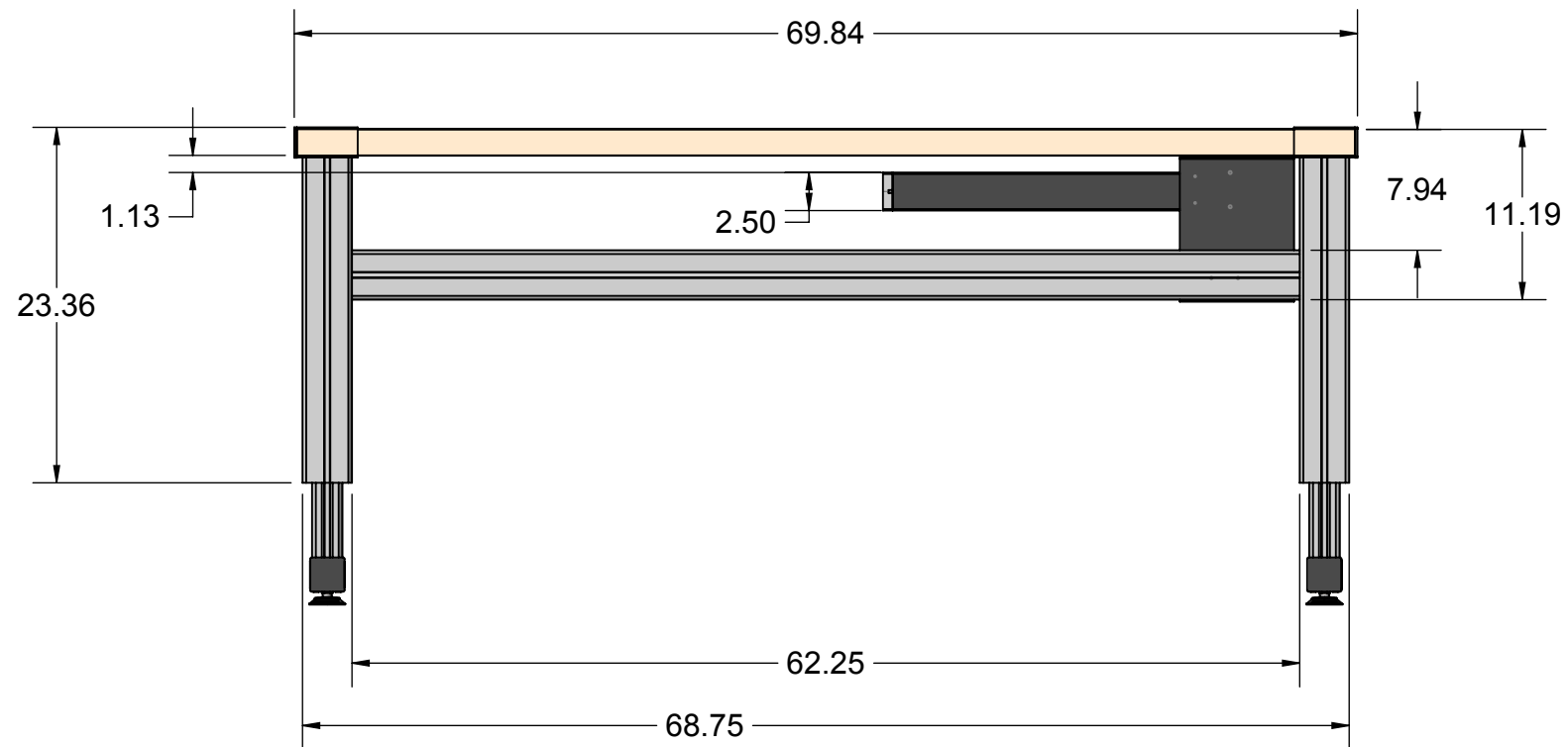

STANDARD TOLERANCES UNLESS OTHERWISE SPECIFIED DIMENSIONS ARE IN INCHES.		DRAWN BY LUCID LABS	DATE 03JUL2013	ErgoSource	THIS DRAWING AND INFORMATION CONTAINED THEREON ARE CONFIDENTIAL AND THE PROPERTY OF ErgoSource. ANY USE OR REPRODUCTION OF THIS DRAWING IS EXPRESSLY PROHIBITED WITHOUT LUCID LABS CONSENT.
INCH .X ±.1 .XX ±.05 ANGLES ±2°		TITLE XET TABLE			
MATERIAL NA			DWG SIZE B		DOCUMENT NUMBER XET 72 INCH
SURFACE TREATMENT (UNLESS OTHERWISE SPECIFIED DIMENSIONS APPLY PRIOR TO TREATMENT) NA			DO NOT SCALE	REVISIONS	REV/VER SHEET 2 OF 2