

VER	DESCRIPTION OF CHANGE
AA	INITIAL RELEASE

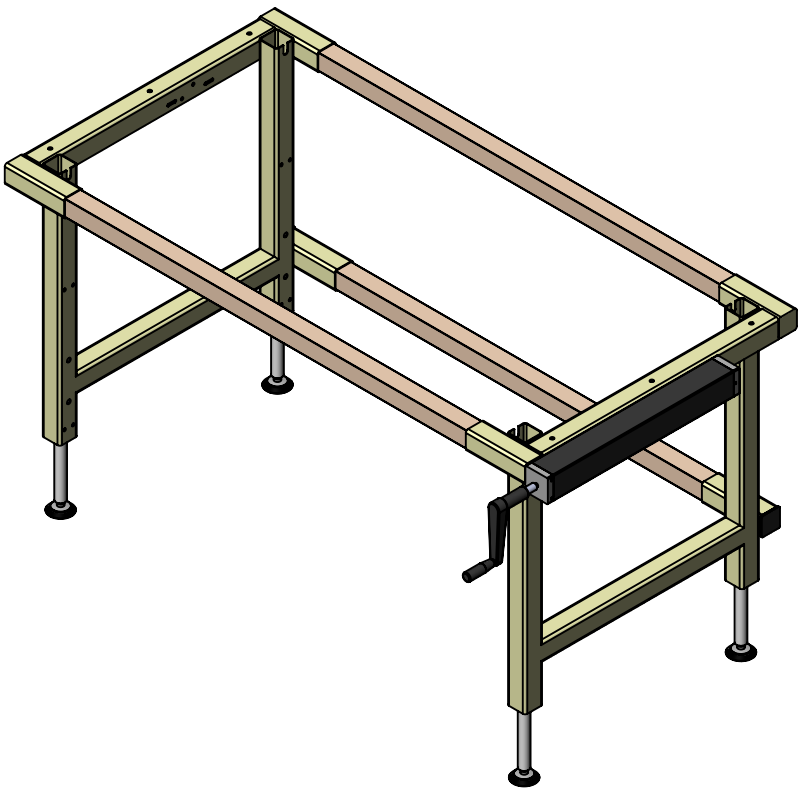
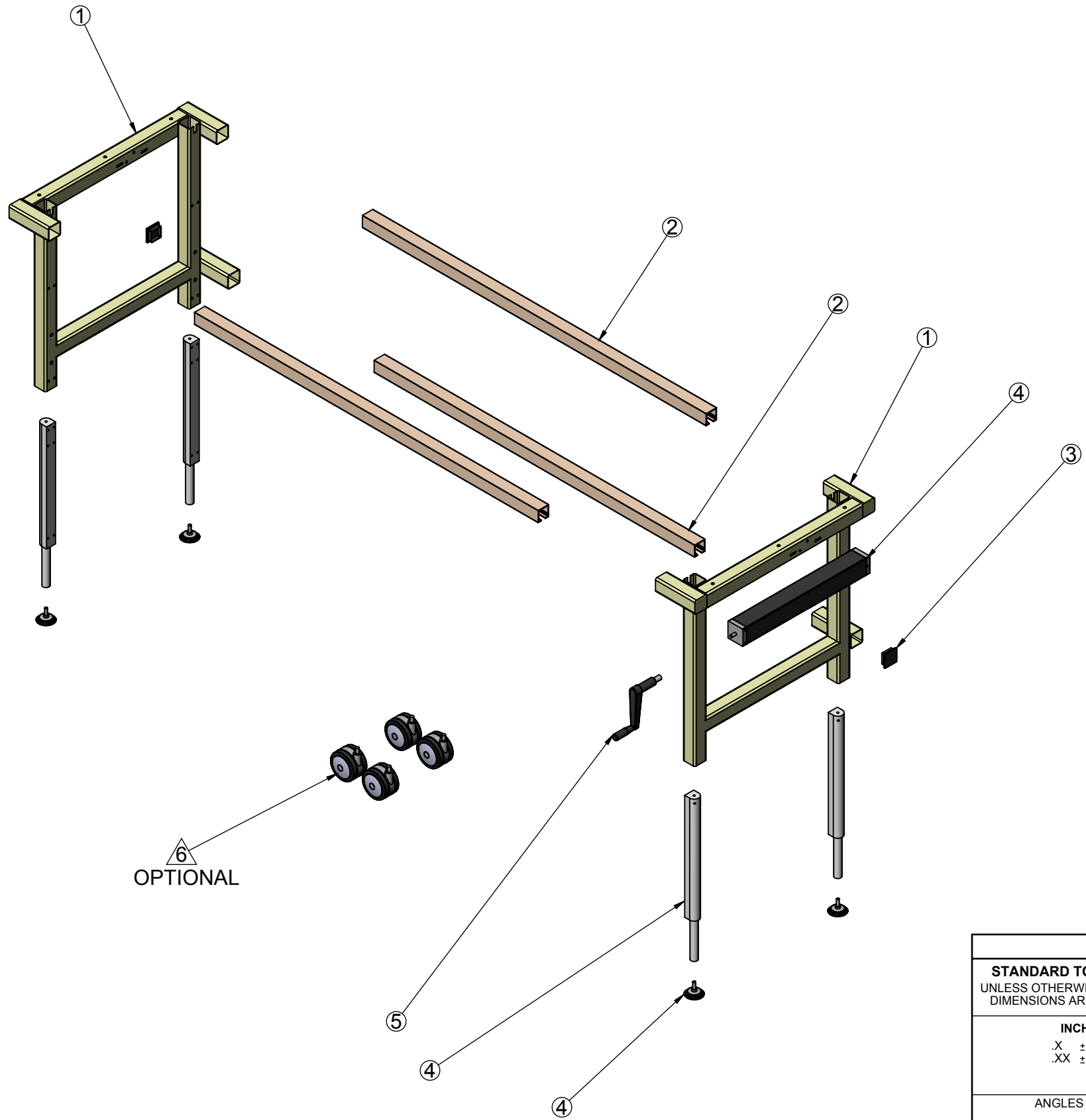

ITEM NO.	QTY.	ADDITIONAL DESCRIPTION	VENDOR	VENDOR PN
1	1	LH4T-EF-SET	ERGOSOURCE	LH4T-EF-SET
2	3	RAIL	ERGOSOURCE	109542-05001CAPP
3	2	END CAP	ERGOSOURCE	SQR-2-10-14
4	1	4X PUMP HOUSING	ERGOSOURCE	LM4X12T - LPHA4-12
5	1	HANDLE	ERGOSOURCE	LH-05ES
6	4	CASTER	ERGOSOURCE	2F9957009-01

6
OPTIONAL

STANDARD TOLERANCES UNLESS OTHERWISE SPECIFIED DIMENSIONS ARE IN INCHES. INCH .X ±.1 .XX ±.05 ANGLES ±2°	DRAWN BY LUCID LABS	DATE 25APR2013		THIS DRAWING AND INFORMATION CONTAINED THEREON ARE CONFIDENTIAL AND THE PROPERTY OF ErgoSource. ANY USE OR REPRODUCTION OF THIS DRAWING IS EXPRESSLY PROHIBITED WITHOUT LUCID LABS CONSENT.
	TITLE LH4T TABLE			
MATERIAL NA SURFACE TREATMENT (UNLESS OTHERWISE SPECIFIED DIMENSIONS APPLY PRIOR TO TREATMENT) NA	DWG SIZE B		DOCUMENT NUMBER LH4T - 60 INCH	REV/VER
			DO NOT SCALE	SHEET 1 OF 2

SOLIDWORKS

VER	DESCRIPTION OF CHANGE
AA	INITIAL RELEASE

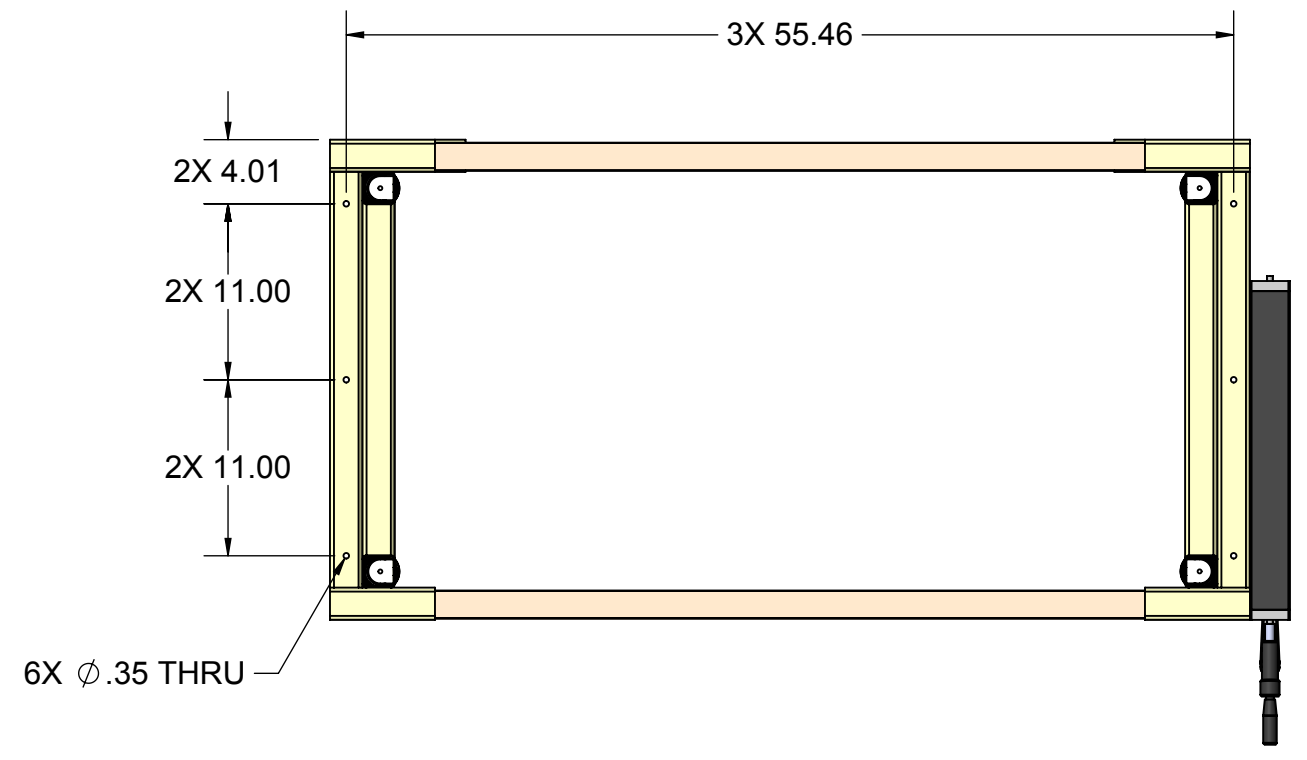
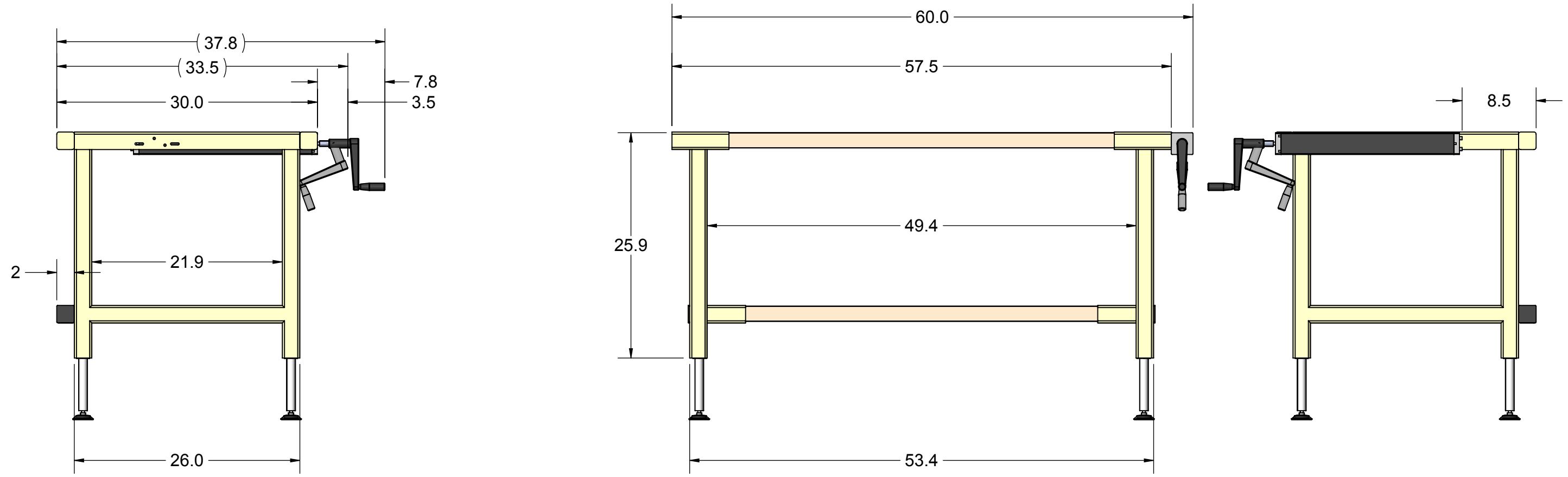

STANDARD TOLERANCES UNLESS OTHERWISE SPECIFIED DIMENSIONS ARE IN INCHES.		DRAWN BY LUCID LABS	DATE 25APR2013	ErgoSource	THIS DRAWING AND INFORMATION CONTAINED THEREON ARE CONFIDENTIAL AND THE PROPERTY OF ErgoSource. ANY USE OR REPRODUCTION OF THIS DRAWING IS EXPRESSLY PROHIBITED WITHOUT LUCID LABS CONSENT.
INCH .X ±.1 .XX ±.05	TITLE LH4T TABLE				
ANGLES ±2°				DWG SIZE B	THIRD ANGLE PROJECTION
MATERIAL NA				DOCUMENT NUMBER LH4T - 60 INCH	REV/VER
SURFACE TREATMENT (UNLESS OTHERWISE SPECIFIED DIMENSIONS APPLY PRIOR TO TREATMENT) NA				DO NOT SCALE	SHEET 2 OF 2

SOLIDWORKS