

REV/VER	DESCRIPTION OF CHANGE
AA	INITIAL RELEASE

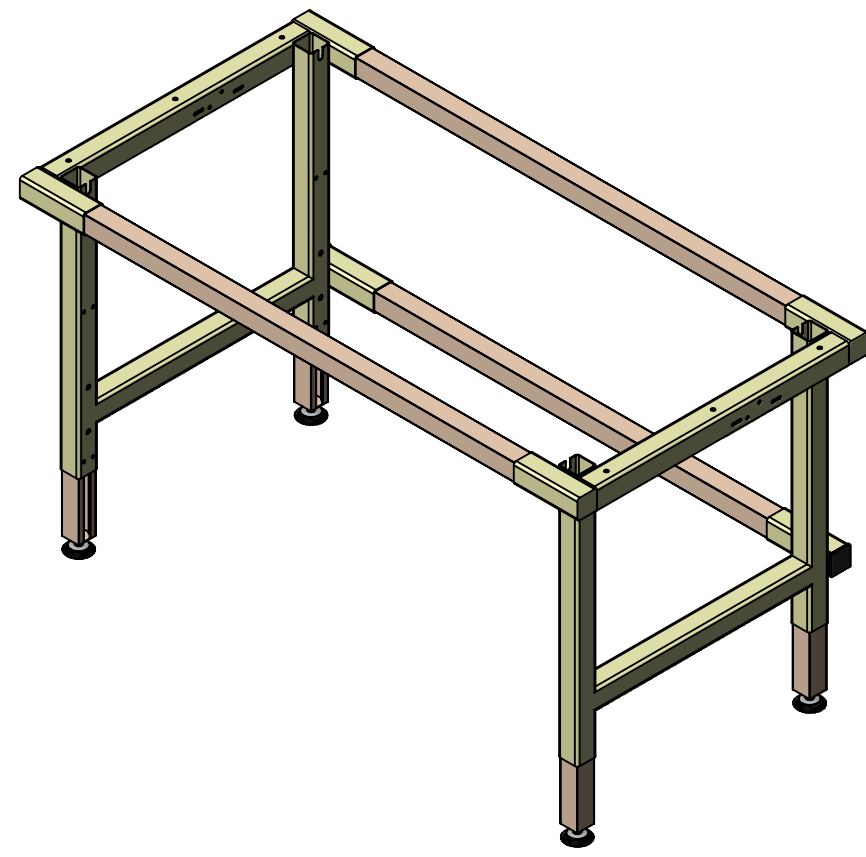
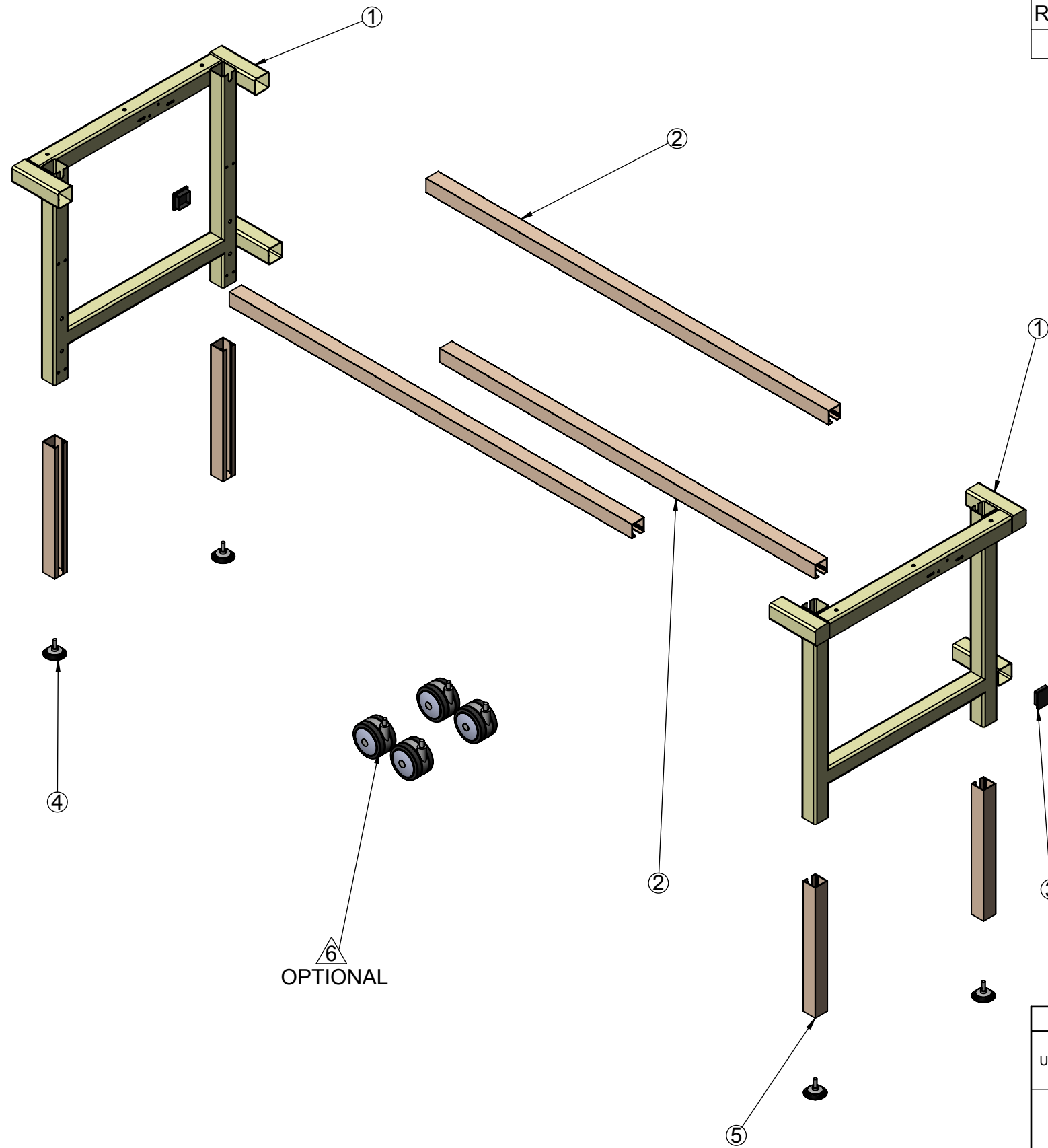

ITEM NO.	QTY.	ADDITIONAL DESCRIPTION	VENDOR	VENDOR PN
1	1	LH4T-EF-SET	ERGOSOURCE	LH4T-EF-SET
2	3	RAIL	ERGOSOURCE	109542-05001CAPP
3	2	END CAP	ERGOSOURCE	SQR-2-10-14
4	4	GLIDE FOOT	ERGOSOURCE	7661-6-B-2
5	4	LEG RAIL	ERGOSOURCE	21" 109542-05001CAPP & LWS-5EP
6	4	CASTER	ERGOSOURCE	2F9957009-01

STANDARD TOLERANCES UNLESS OTHERWISE SPECIFIED DIMENSIONS ARE IN INCHES. INCH .X ±.1 .XX ±.05 ANGLES ±2°	DRAWN BY LUCID LABS	DATE 08JUL2013		THIS DRAWING AND INFORMATION CONTAINED THEREON ARE CONFIDENTIAL AND THE PROPERTY OF ErgoSource. ANY USE OR REPRODUCTION OF THIS DRAWING IS EXPRESSLY PROHIBITED WITHOUT LUCID LABS CONSENT.
	TITLE LF4T TABLE			
MATERIAL NA SURFACE TREATMENT (UNLESS OTHERWISE SPECIFIED DIMENSIONS APPLY PRIOR TO TREATMENT) NA	DWG SIZE B		DOCUMENT NUMBER LF4T 60 INCH	REV/VER
			DO NOT SCALE	SHEET 1 OF 2

SOLIDWORKS

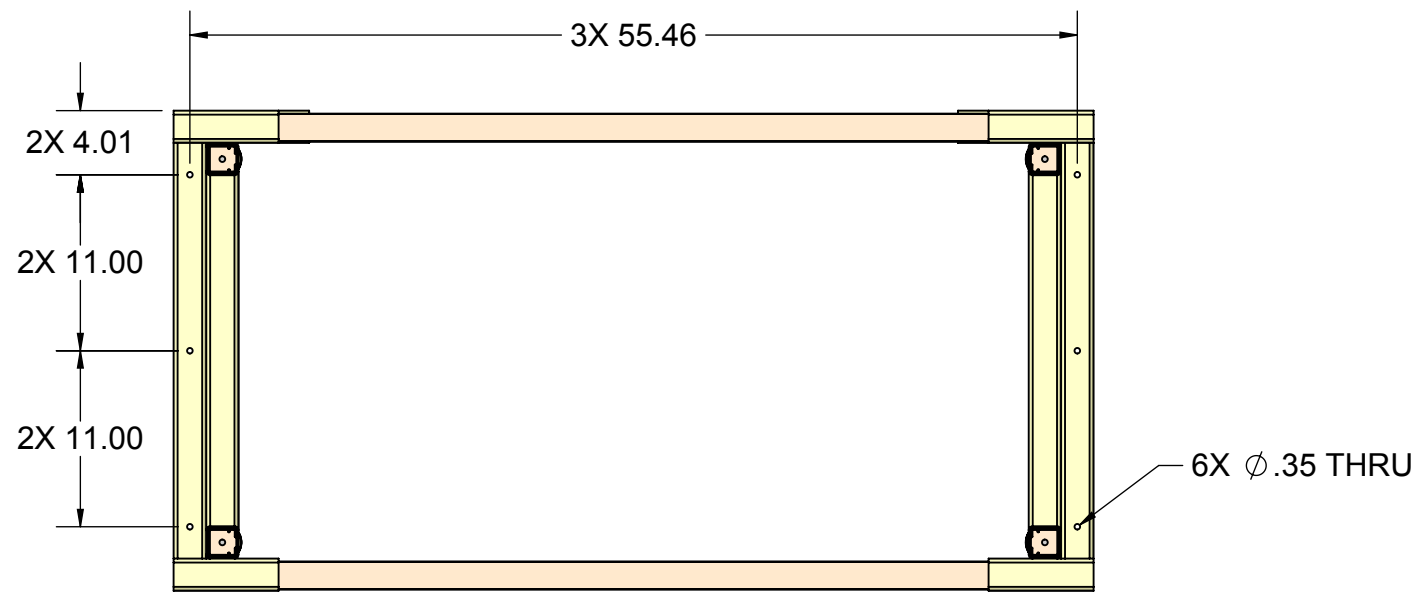
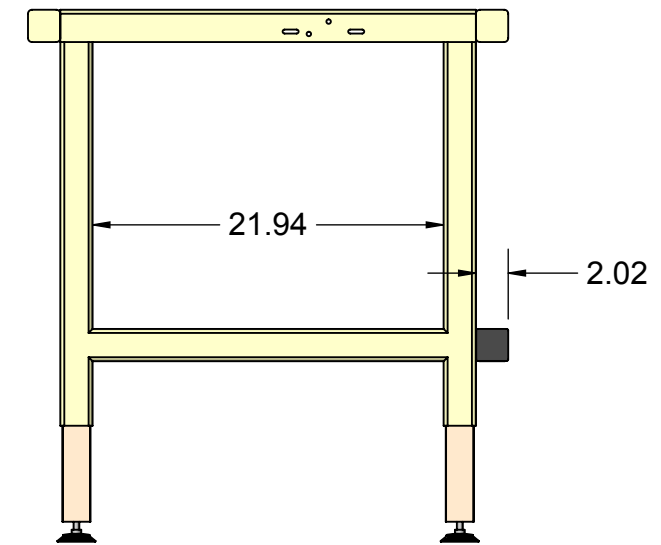
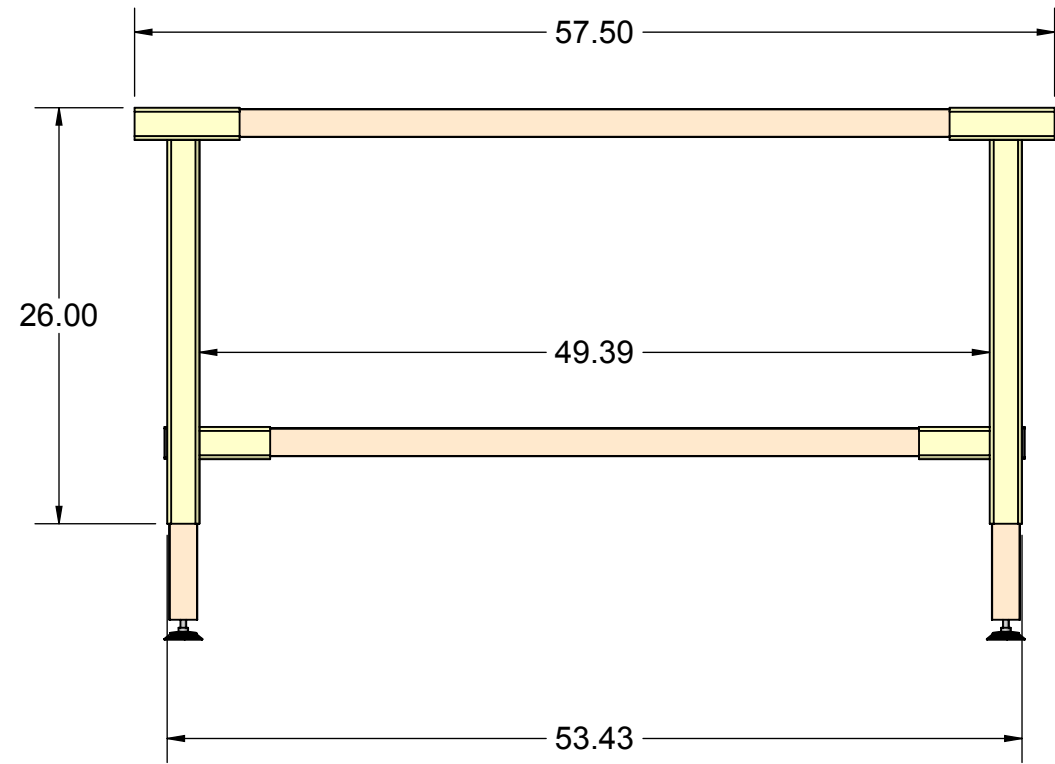

STANDARD TOLERANCES UNLESS OTHERWISE SPECIFIED DIMENSIONS ARE IN INCHES.		DRAWN BY LUCID LABS	DATE 08JUL2013	ErgoSource	THIS DRAWING AND INFORMATION CONTAINED THEREON ARE CONFIDENTIAL AND THE PROPERTY OF ErgoSource. ANY USE OR REPRODUCTION OF THIS DRAWING IS EXPRESSLY PROHIBITED WITHOUT LUCID LABS CONSENT.
INCH .X ±.1 .XX ±.05 ANGLES ±2°		TITLE LF4T TABLE			
MATERIAL NA			DWG SIZE B		DOCUMENT NUMBER LF4T 60 INCH
SURFACE TREATMENT (UNLESS OTHERWISE SPECIFIED DIMENSIONS APPLY PRIOR TO TREATMENT) NA			DO NOT SCALE		REV/VER SHEET 2 OF 2