

REV/VER	DESCRIPTION OF CHANGE
AA	INITIAL RELEASE

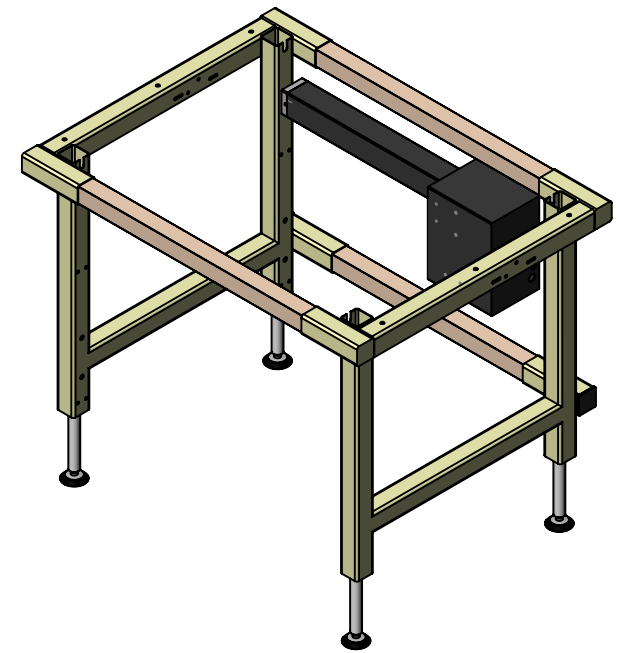
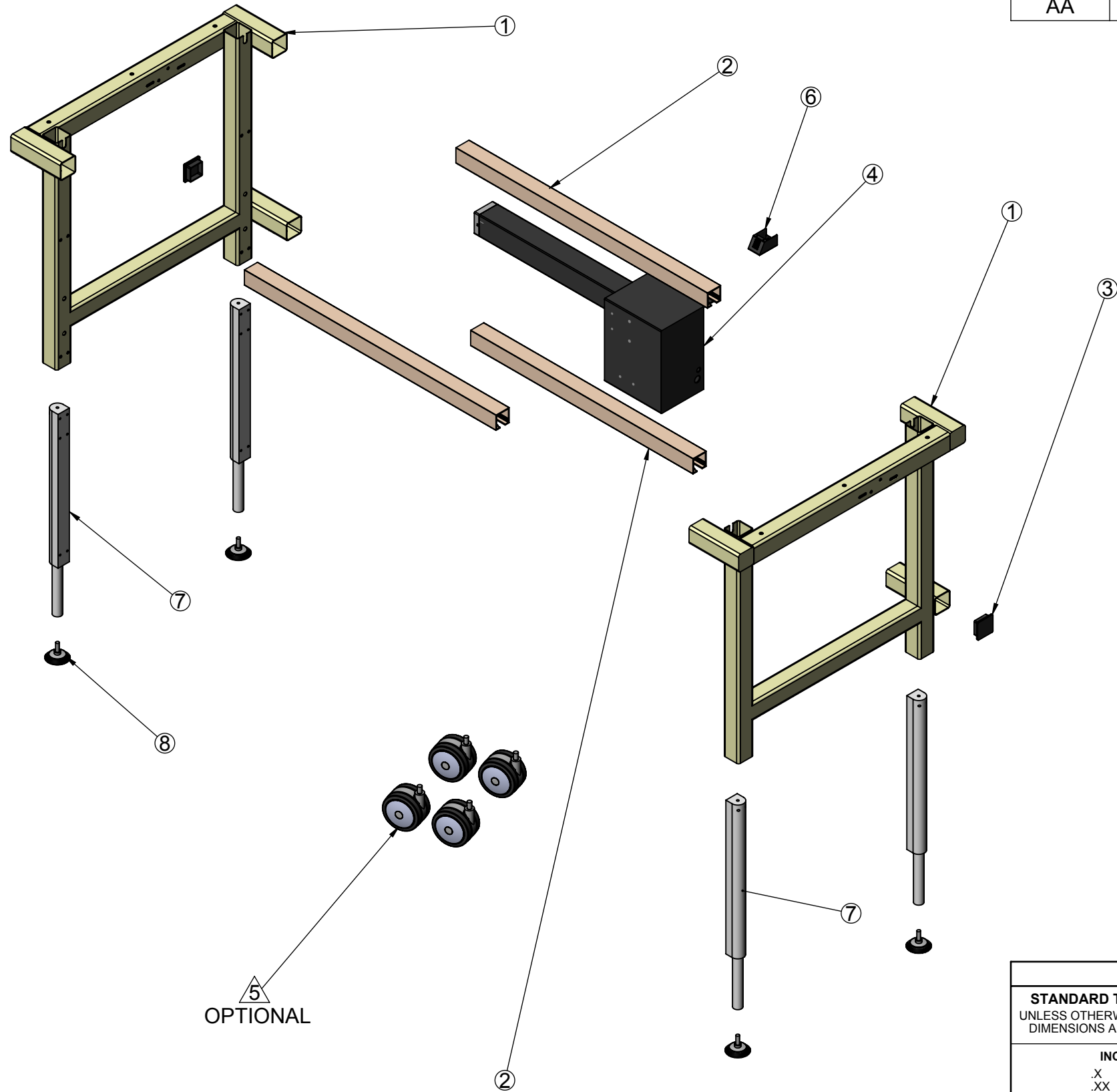

ITEM NO.	QTY.	ADDITIONAL DESCRIPTION	VENDOR	VENDOR PN
1	1	LH4T-EF-SET	ERGOSOURCE	LH4T-EF-SET
2	3	RAIL	ERGOSOURCE	109542-05001CAPP
3	2	END CAP	ERGOSOURCE	SQR-2-10-14
4	1	LIFT SYSTEM	ERGOSOURCE	LE4X12T - LPE4A-12
5	4	CASTER	ERGOSOURCE	2F9957009-01
6	1	SWITCH ASSEMBLY	ERGOSOURCE	1065-RS
7	4	X-HOUSING	ERGOSOURCE	X-HOUSING
8	4	GLIDE FOOT	ERGOSOURCE	7661-6-B-2

<b>STANDARD TOLERANCES</b> UNLESS OTHERWISE SPECIFIED DIMENSIONS ARE IN INCHES.		<b>DRAWN BY</b> LUCID LABS	<b>DATE</b> 02JUL2013	<b>ErgoSource</b>	THIS DRAWING AND INFORMATION CONTAINED THEREON ARE CONFIDENTIAL AND THE PROPERTY OF ErgoSource. ANY USE OR REPRODUCTION OF THIS DRAWING IS EXPRESSLY PROHIBITED WITHOUT LUCID LABS CONSENT.
<b>INCH</b> .X ±.1 .XX ±.05	<b>TITLE</b> LE4T TABLE				
ANGLES ±2°	<b>MATERIAL</b> NA		<b>DWG SIZE</b> B	<b>THIRD ANGLE PROJECTION</b>	<b>DOCUMENT NUMBER</b> LE4T - 42 INCH
<b>SURFACE TREATMENT (UNLESS OTHERWISE SPECIFIED DIMENSIONS APPLY PRIOR TO TREATMENT)</b> NA			<b>DO NOT SCALE</b>	<b>REVISION</b> SHEET 1 OF 2	

SOLIDWORKS

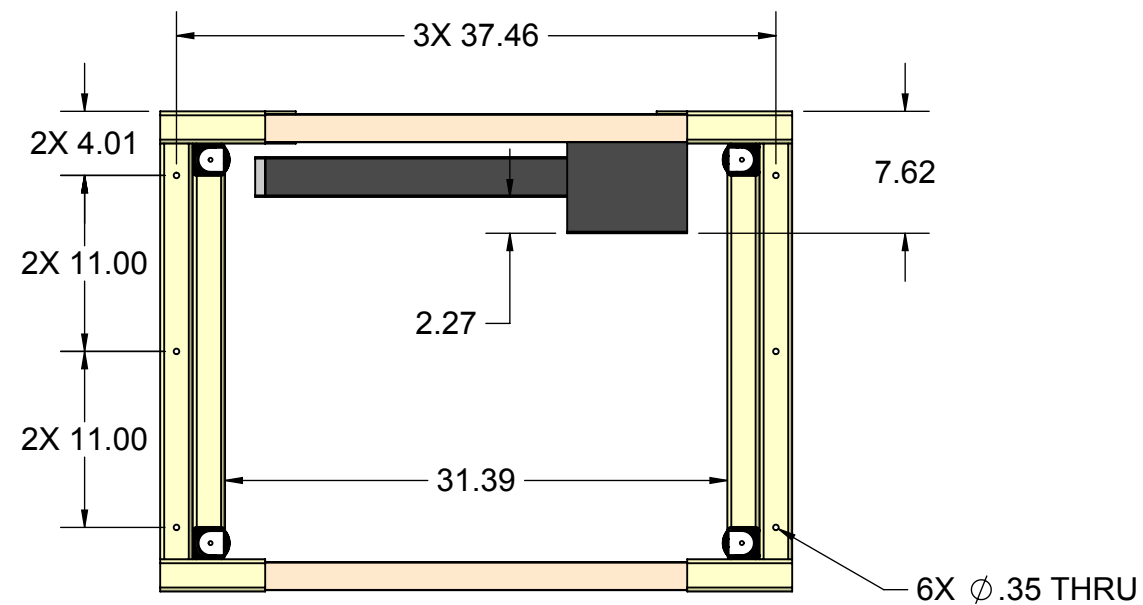
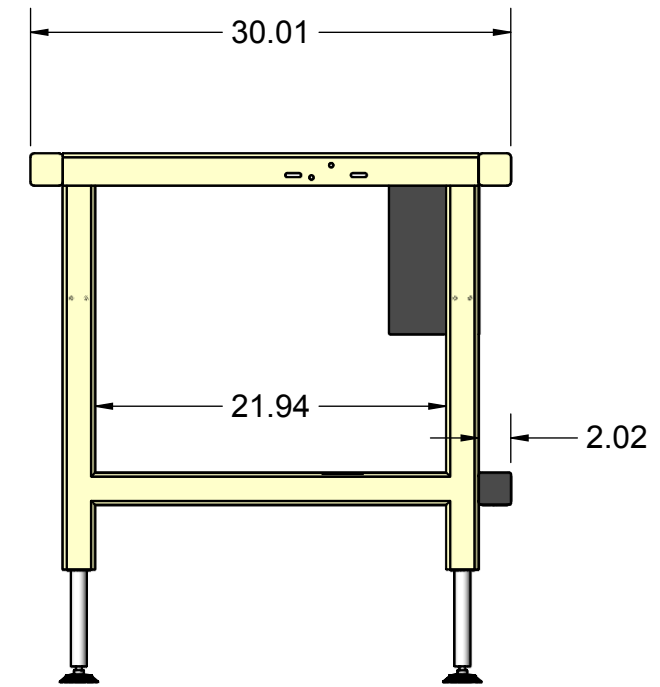
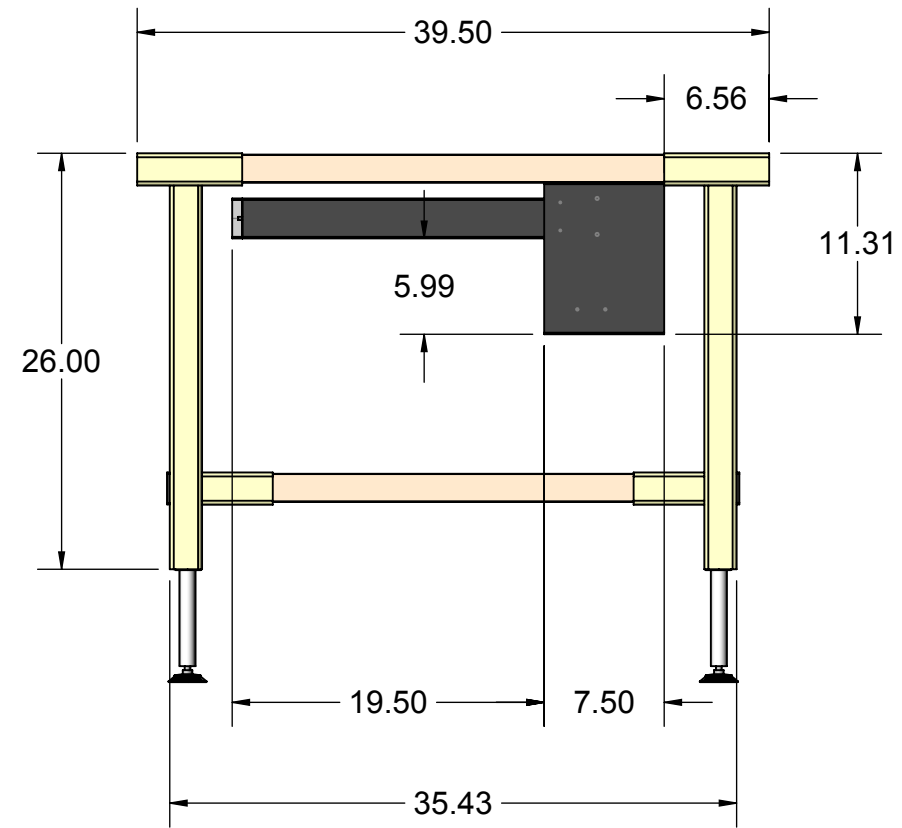

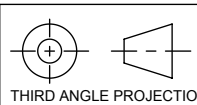
<b>STANDARD TOLERANCES</b> UNLESS OTHERWISE SPECIFIED DIMENSIONS ARE IN INCHES.		<b>DRAWN BY</b> LUCID LABS	<b>DATE</b> 02JUL2013	<b>ErgoSource</b>	THIS DRAWING AND INFORMATION CONTAINED THEREON ARE CONFIDENTIAL AND THE PROPERTY OF ErgoSource. ANY USE OR REPRODUCTION OF THIS DRAWING IS EXPRESSLY PROHIBITED WITHOUT LUCID LABS CONSENT.	
<b>INCH</b> .X ±.1 .XX ±.05  <b>ANGLES</b> ±2°		<b>TITLE</b> LE4T TABLE				
<b>MATERIAL</b> NA			<b>DWG SIZE</b> B	 THIRD ANGLE PROJECTION	<b>DOCUMENT NUMBER</b> LE4T - 42 INCH	<b>REV/VER</b>
<b>SURFACE TREATMENT</b> (UNLESS OTHERWISE SPECIFIED DIMENSIONS APPLY PRIOR TO TREATMENT) NA			<b>DO NOT SCALE</b>		<b>SHEET</b> 2 OF 2	